

- NOTES-**
- RANGE SWITCH SHOWN IN BROADCAST POSITION. VIEWED FROM FRONT WITH CHASSIS IN AN INVERTED POSITION.
 - WHEN A PM SPEAKER IS USED -
R-22 & R-23 SHOWN IN DOTTED LINES ARE TO BE ADDED.
THE CONNECTION MARKED "X" IS TO BE BROKEN.
 - R-24 IS USED ON THE 674-H ONLY, R-6 IS USED ON 674-P & 674-PS ONLY
 - PEAKING COIL L-22 USED ON 674-P ONLY

CHASSIS LAYOUT

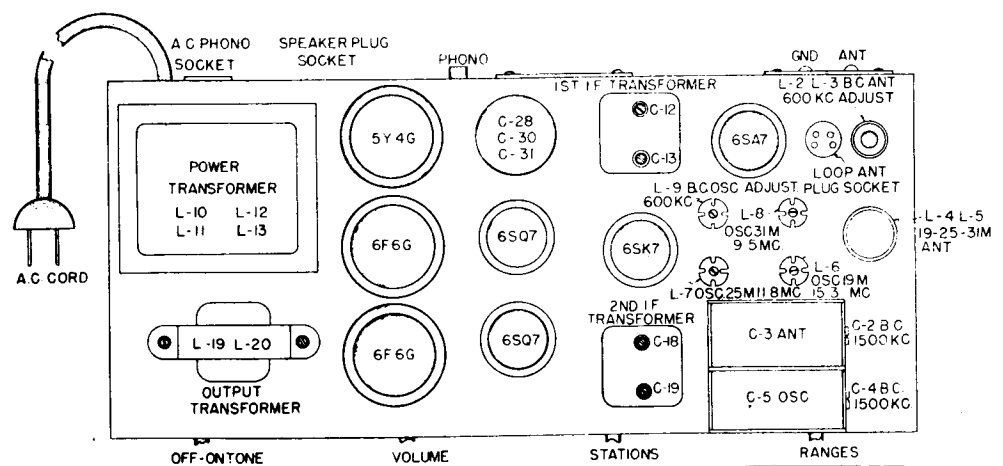

**1946-47
A-C MODEL
674**

I.F.=460kc

Alignment and Voltages on Data Sheet 75

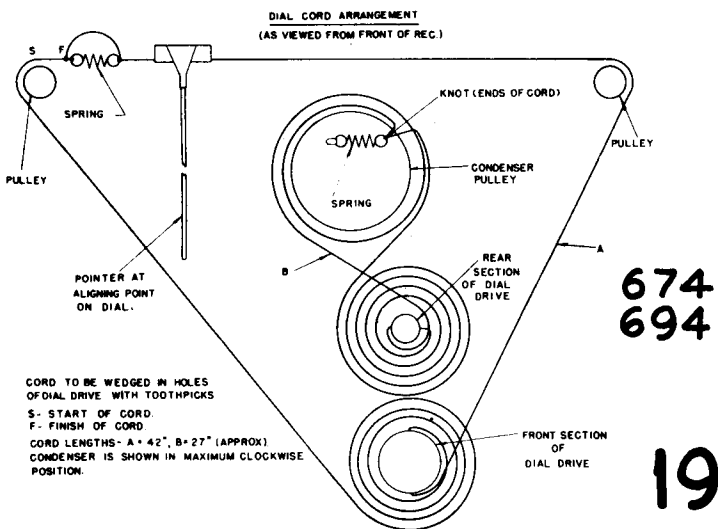

674
694

INSTRUCTION DATA MODEL 694

- 2. Intermediate Frequency Adjustments.**
- Set the range switch to "A" broadcast position.
 - Set the pointer to the extreme low frequency end of the dial.
 - Connect the ground terminal of the signal generator to the chassis ground terminal.
 - Introduce a modulated 460 kilocycle signal to the "signal" grid of the 6SA7 modulator tube (#8 terminal or C₁), using a .1 mfd. capacitor in series with the output lead from the signal generator.
 - Adjust the I.F. 460KC trimmers for maximum output in the following order:
 - Secondary of 2nd I.F. transformer C21
 - Primary of 2nd I.F. transformer C20
 - Secondary of 1st I.F. transformer C16
 - Primary of 1st I.F. transformer C15
 Repeat A, B, C, D for maximum results.
- 3. Radio Frequency Adjustments.**
- Broadcast Range**
- Set the range switch to broadcast "A" band.
 - Set the signal generator frequency and the receiver tuning dial to 1500 KC.
 - Connect a 200 mmfd. capacitor in series with the antenna lead from the signal generator to the "Ant." terminal on the set, replacing the .1 mfd. capacitor.
 - Adjust the "A" band oscillator trimmer C33 for maximum signal and correct calibration.
 - Adjust the "R.F." and "Ant." trimmers C₁ and C₂ for maximum output. "Rock" the gang to obtain maximum peak.
 - Tune the receiver dial and the signal generator to 600KC.
 - Adjust the iron core of the "BC" oscillator coil L19 for correct calibration at 600KC.
 - Adjust the iron cores of the "RF" and "Ant." coils L7 and L2 for maximum sensitivity. "Rock" the gang during adjustment.
 - Repeat 3.5 and 3.8 until further adjustment at either 1500KC or 600 KC makes no improvement in performance.
- 4. Shortwave Spreadband Ranges.**
- Set the range switch to "B" 31 meter band.
 - Set the signal generator frequency and the receiver tuning dial to 9.500 megacycles.
 - Connect a 400 ohm carbon resistor in series with the antenna lead from the signal generator to the "Ant." terminal on the set, replacing the 200 mmfd. capacitor.
 - Adjust L18 Osc. 31M: Band-Centering screw for maximum signal and correct calibration.
 - Check sensitivity at 9.350 and 9.850 megacycles.
 - Set the range switch to "C" 25 meter band and the signal generator frequency to 11.8 megacycles.
 - Adjust L17 Osc. 25M band-centering screw for maximum signal and correct calibration.
 - Check sensitivity at 11.500 and 12.100 megacycles.
 - Set the range switch to "D" 19 meter band and the signal generator frequency to 15.300 megacycles.
 - Adjust L16 Osc. 19M band-centering screw for maximum signal and correct calibration.
 - Check sensitivity at 14.800 and 15.650 megacycles.

Since the average service oscillator is not, as a rule, calibrated finely enough to be set to the above band "center-frequencies" it is always advisable to check the spreadband ranges on actual reception of shortwave stations of known frequency.

NORMAL VOLTAGE READINGS—MODEL 694

Tube	Circuit	Socket Terminals								
		1	2	3	4	5	6	7	8	
6SG7	R.F. Amplifier			.25		90	5.8	300		
6SA7	Modulator-Oscillator			280	110	-.5	5.8			
6SF7	I.F. Amplifier Demodulator & AVC			70		280	5.8			
6C5	1st Audio Amplifier			120	210		5.8	5		
6SC7	2nd Audio and Phase Inverter		140			150	2	5.8		
6L6G	Push-Pull Output			340	290		340	5.8	20	
6L6G	Push-Pull Output			340	290		5.8	20		
5U4G	Rectifier			360		325		360		
6U5-6G5	Tuning Indicator	5.8	1		200					

NORMAL VOLTAGE READINGS

Take all readings with the chassis operating and tuned to 1000 Kc—no signal. Use a line voltage of 117 volts or make allowance for any variations. Use a good high resistance voltmeter having a resistance of at least 1000 ohms per volt. Read from the indicated terminals to chassis base. See the location chart for position of sockets. AC voltages are indicated by italics.

ALIGNING INFORMATION

Never Re-align Unless Absolutely Necessary

Use a good modulated signal generator (test oscillator with variable R.F. output voltage) and a sensitive output meter across the voice coil of the speaker.

Always align using the smallest possible input from the signal generator, as a strong signal makes adjustments inaccurate. Always turn the receiver volume control "Full on".

Be sure the Broadcast Loop is plugged into its socket when alignment of the Broadcast Band is made.

ALIGNING PROCEDURE (Follow this order exactly)

- Dial Pointer Adjustment**

With the plates of the gang condenser fully engaged, check to be sure the dial pointer is in a vertical position directly on the calibration mark located at the low frequency end of the dial scale. It appears as a small gold dot at the lower left hand corner of the dial opening. Adjust if necessary.
- Intermediate Frequency Adjustments**
 - Set the range switch to "BC" broadcast position.
 - Set the pointer to the extreme low frequency end of the dial.
 - Connect the ground terminal of the signal generator to the chassis ground terminal.
 - Introduce a modulated 460 kilocycle signal to the RF grid of the 6SA7 modulator tube (#8 terminal or C₁), using a .1 mfd. capacitor in series with the output lead of the signal generator.
 - Adjust the I.F. 460 Kc. trimmers for maximum output in the following order:
 - Secondary of 2nd IF transformer C19
 - Primary of 2nd IF transformer C18
 - Secondary of 1st IF transformer C13
 - Primary of 1st IF transformer C12

- Radio Frequency Adjustments**

Broadcast Range

 - Set the range switch to Broadcast ("A")
 - Set the signal generator frequency and the receiver tuning dial to 1500 Kc.
 - Connect a 200 mmfd capacitor in series with the antenna lead from the signal generator to the "Ant." terminal on the set, replacing the .1 mfd capacitor.
 - Adjust the "BC" band oscillator trimmer C4 for maximum signal and correct calibration.
 - Adjust the antenna trimmer C2 for maximum output. "Rock" the gang to obtain maximum peak.
 - Check calibration and sensitivity at 600 Kc. Adjust "BC Ant. 600 Kc adjust" for maximum sensitivity.
 - Repeat 3.4 and 3.5 until further adjustment at either 1500 Kc or 600 Kc makes no improvement in performance.

Shortwave Spreadband Ranges

 - Set the Range Switch to "B" 31 meter band.
 - Set the signal generator frequency and the receiver tuning dial to 9.500 megacycles.
 - Connect a 400 ohm carbon resistor in series with the antenna lead from the signal generator to the "Ant" terminal on the set, replacing the 200 mmfd. capacitor.
 - Adjust L8 "Osc. 31M" Band-centering screw for maximum signal and correct calibration.
 - Check sensitivity at 9.250 and 9.750 megacycles.
 - Set the range switch to "C" 25 meter band, and the signal generator frequency to 11.8 mcs.
 - Adjust L7 "Osc. 25M" band-centering screw for maximum signal and correct calibration.
 - Check sensitivity at 11.500 and 12.000 megacycles.
 - Set the range switch to "D" 19 meter band and the signal generator frequency to 15.3 mcs.
 - Adjust L6 "Osc. 19M" band-centering screw for maximum signal and correct calibration.
 - Check sensitivity at 14.900 and 15.600 megacycles.

674P AND PS VOLTAGE CHART

Tube	Type	1	2	3	4	5	6	7	8
6SA7	Osc. Modulator	0	0	290	132	-1.25	0	5.8	0
6SK7	IF Amp.	0	0	0	0	0	225	5.6	290
6SQ7	Dem. AVC / 1st Audio	0	0	0	0	0	90	5.6	0
6SQ7	Phase Inverter	0	0	0	0	0	85	5.6	0
6F6G	Output	0	0	270	280	0	0	5.6	0
6F6G	Output	0	0	270	280	0	0	5.6	0
5Y4G	Rect.			360		360		4.6	
Speaker Socket		300	0	0	400	400	0	400	

674H VOLTAGE CHART

Tube	Type	1	2	3	4	5	6	7	8
6SA7	Osc. Modulator	0	0	260	115	1.25	0	6	0
6SK7	IF Amp.	0	0	0	0	0	137	6	280
6SQ7	Dem. AVC / 1st. Audio	0	0	0	0	0	75	6	0
6SQ7	Phase Inverter	0	0	0	0	0	75	6	0
6F6G	Output	0	0	290	260	0	0	6	17
6F6G	Output	0	0	290	260	0	0	6	17
5Y4G	Rect.			320		320		4.6	4.6
Speaker Socket		260	0	0	400	400	0	400	

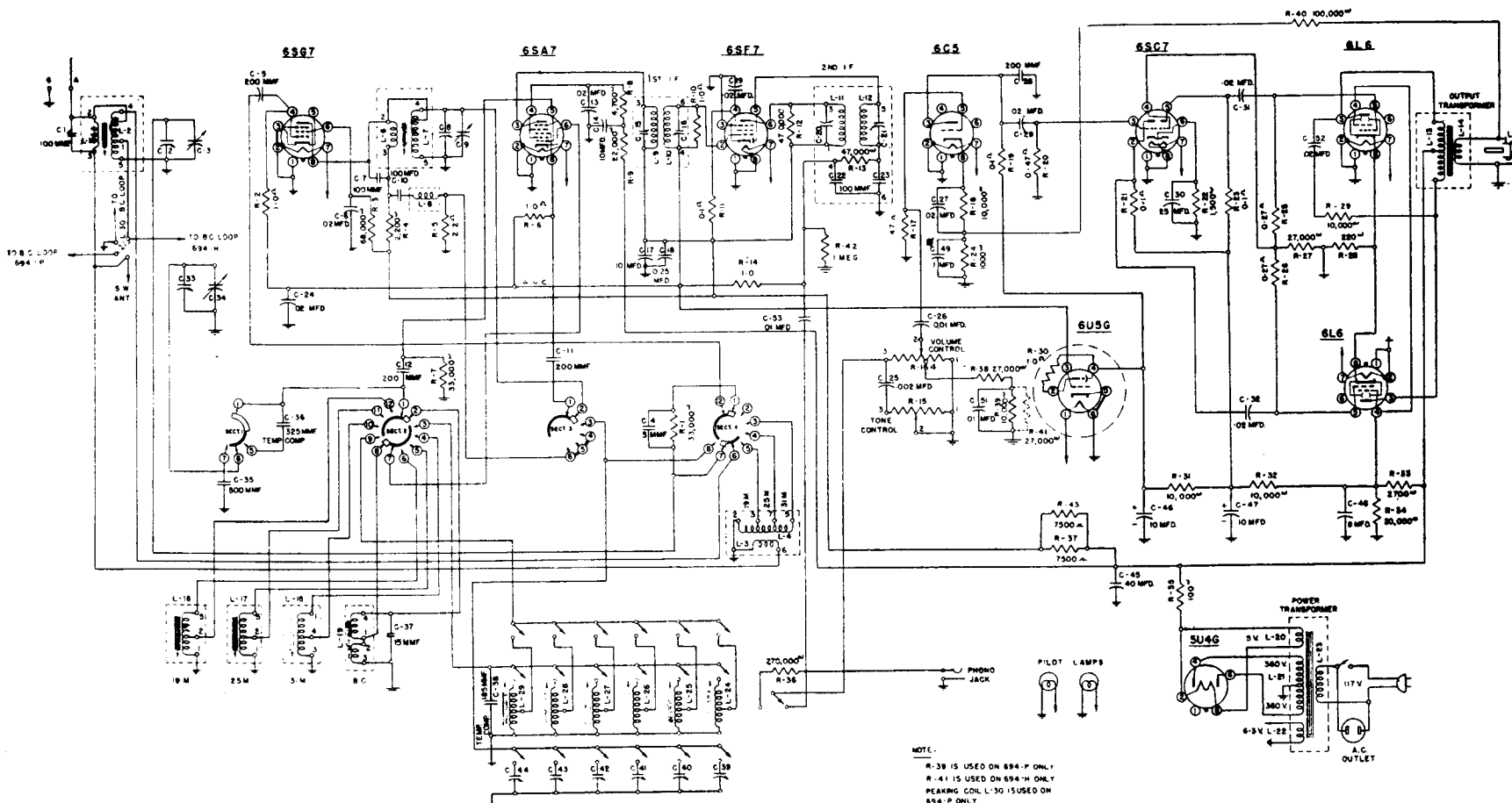

NOTE:
 R-39 IS USED ON 694-P ONLY
 R-41 IS USED ON 694-H ONLY
 PEAKING COIL L-30 IS USED ON
 694-P ONLY

* To Reduce Needle Hiss
 Remove C-49

I.F. = 460Kc.

1946-47 A-C MODEL 694

Further Data on
 Sheet 75

